



MT40 Linear Image Barcode Scan Engine, Integration Guide, V1.7

MT40
(3.3~5V Long Range Barcode Scan Engine)

MT40W
(3.3~5V Wide Angle Barcode Scan Engine)

Integration Guide

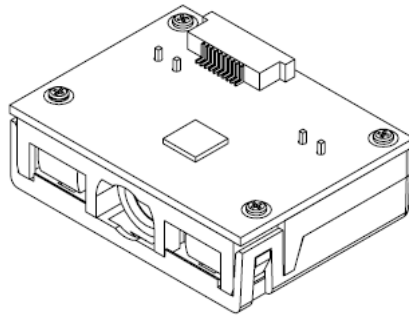



TABLE OF CONTENTS

1. INTRODUCTION	1
1-1. MT40 Block Diagram	1
1-2. Electric Interface	2
1-2-1. Pin Assignment	2
1-2-2. Electric Characteristics	5
1-2-3. Flex Cable	5
1-3. Operational Timing	6
1-3-1. Power Up	6
1-3-2. Sleep (Idle) Mode	6
1-3-3. Decode Timing	6
1-3-4. Summary of Operation Timings	7
2. SPECIFICATIONS	8
2-1. Introduction	8
2-2. Technical Specifications	8
2-3. Interface	10
2-3-1. UART Interface	10
2-3-2. USB Interface	11
2-4. Operation Method	12
2-5. Mechanical Dimension	12
2-6. Scanning Range	13
2-7. Pitch Angle, Roll Angle and Skew Angle	15
2-8. Specular Dead Zone	16
2-9. Curvature Degree	17
2-10. Flex Cable Specification	17
2-11. Screw Specification	18
2-12. Connector Specification	18
3. INSTALLATION	19
3-1. Electrostatic Discharge Cautions	19
3-2. Mechanical Dimension	19
3-3. Window Materials	20
3-4. Window Specifications	21
3-5. Window Care	24
4. REGULATIONS	24
5. DEVELOPMENT KIT	25
6. SLEEP (IDLE) MODE	26
7. PARAMETER SETUP	27
8. VERSION HISTORY	28

1. INTRODUCTION

The MT40 Linear Image Barcode Scan Engine is designed for 1D high performance barcode scanning with optimal performance and easy integration. MT40 is ideal for integration into data terminals and other small mobile devices. Wide-angle version (MT40W) is also available.

The MT40 consists of 2 illumination LEDs, a high-quality linear image sensor and a microprocessor that contains powerful firmware to control all aspects of operations and enable communication with the host system over the standard set of communication interfaces.

Two interfaces, UART & USB, are available. UART interface communicates with the host system over TTL-level RS232 communication; USB interface emulates a USB Keyboard device and communicates with the host system over USB.

1-1. MT40 Block Diagram

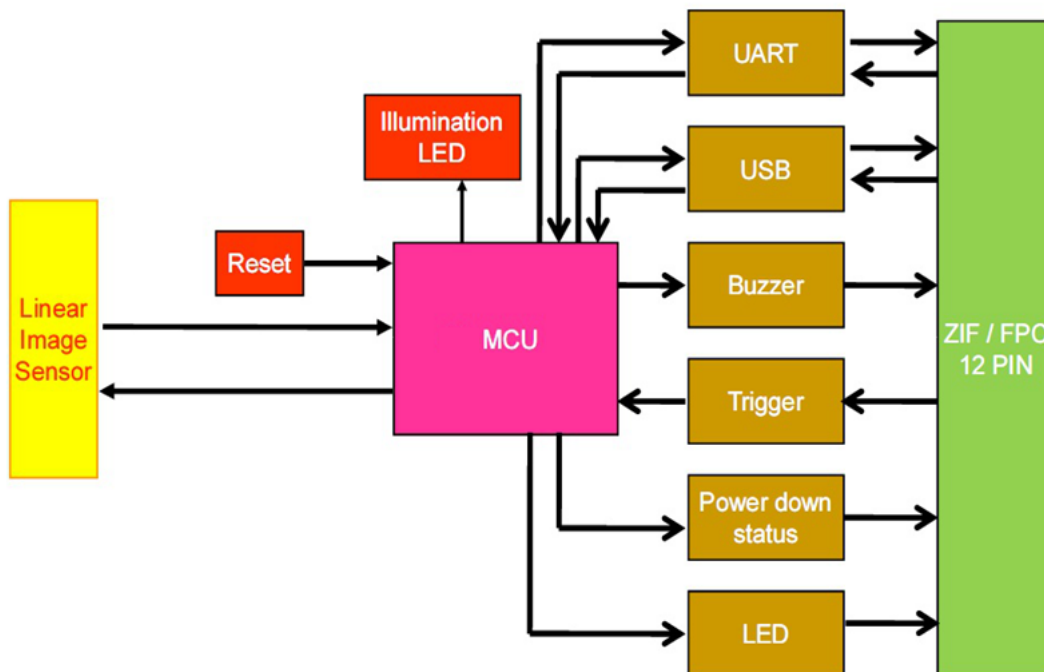

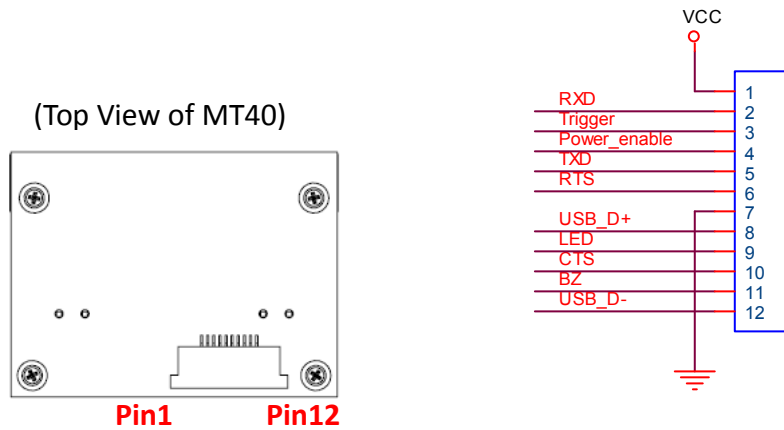

1-2. Electric Interface

1-2-1. Pin Assignment

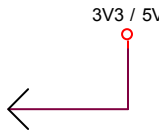
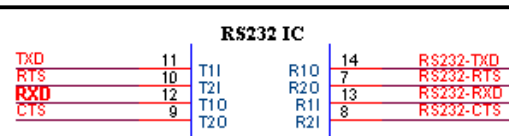
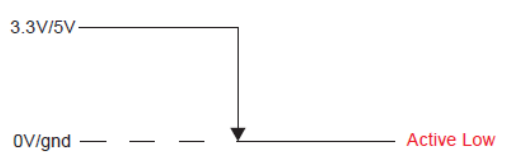

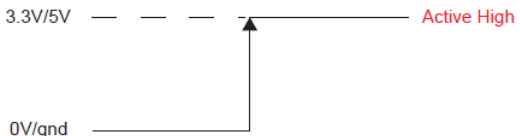
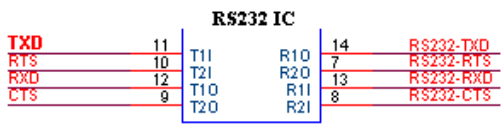
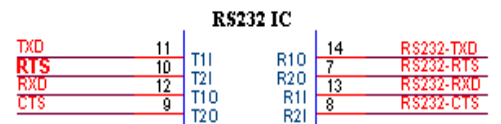
Pin#	UART	USB	I/O	Description	Schematic Example
1	VCC	VCC	-----	Supply voltage input. Must always be connected to 3.3 or 5V power supply.	
2	RXD	-----	Input	UART TTL data input.	 <p>Sipex® Vendor P/N: SP232ACT</p>
3	Trigger	Trigger	Input	High: Power-up/Standby Low: Scanning Operation *Warning: 1. Pull low at power-up will prompt the scan engine into firmware update mode.	 <p>Once trigger is pressed (pull low), scanning operation continues until a barcode is successfully decoded or the trigger is released (pull high). To proceed to the next scanning operation, release (pull high) first and press (pull low) the trigger again.</p>

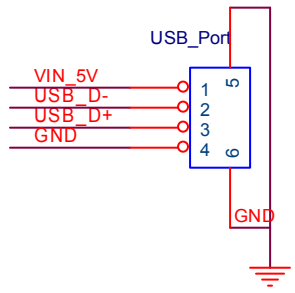
Pin#	UART	USB	I/O	Description	Schematic Example
4	Power Enable	Power Enable	Input	High: Scan Engine Off Low: Scan Engine On *Except: 1. During data transmission 2. Writing parameters to non-volatile memory.	 <p>When Power Enable pin is pull high, scan engine will be shut down with power consumption of less than 1uA.</p>
5	TXD	-----	Output	UART TTL data output.	 <p>Sipex® Vendor P/N: SP232ACT</p>
6	RTS	-----	Output	When handshaking is enabled, MT40 requests permission from host to transmit data on TXD line.	 <p>Sipex® Vendor P/N: SP232ACT</p>
7	GND	GND	-----	Power and signal ground.	
8	-----	USB D+	Bidirectional	Differential Signal Transmission	

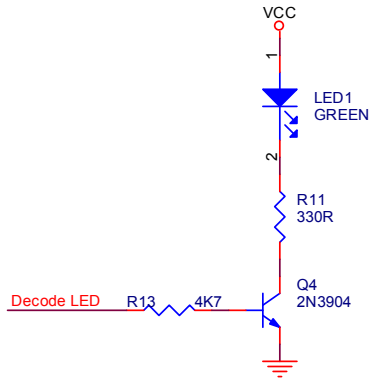
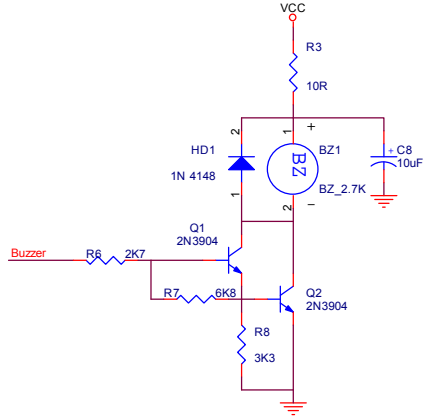
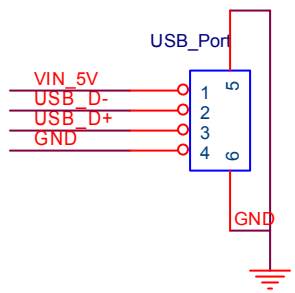
Pin#	UART	USB	I/O	Description	Schematic Example																								
9	LED	LED	Output	Active high, it indicates the status of Power-Up or a successful barcode decoded (Good Read).																									
10	CTS	-----	Input	When handshaking is enabled, host authorizes MT40 to transmit data on TXD line.	<p style="text-align: center;">R5232 IC</p> <table border="1" style="margin-left: auto; margin-right: auto;"> <tr> <td>TXD</td> <td>11</td> <td>T11</td> <td>R10</td> <td>14</td> <td>RS232-TXD</td> </tr> <tr> <td>RTS</td> <td>10</td> <td>T21</td> <td>R20</td> <td>7</td> <td>RS232-RTS</td> </tr> <tr> <td>RXD</td> <td>12</td> <td>T10</td> <td>R11</td> <td>13</td> <td>RS232-RXD</td> </tr> <tr> <td>CTS</td> <td>9</td> <td>T20</td> <td>R21</td> <td>8</td> <td>RS232-CTS</td> </tr> </table> <p style="text-align: center;">Sipex® Vendor P/N: SP232ACT</p>	TXD	11	T11	R10	14	RS232-TXD	RTS	10	T21	R20	7	RS232-RTS	RXD	12	T10	R11	13	RS232-RXD	CTS	9	T20	R21	8	RS232-CTS
TXD	11	T11	R10	14	RS232-TXD																								
RTS	10	T21	R20	7	RS232-RTS																								
RXD	12	T10	R11	13	RS232-RXD																								
CTS	9	T20	R21	8	RS232-CTS																								
11	Buzzer	Buzzer	Output	Active high: Power-Up or a successful barcode decoded. PWM controlled signal can be used to drive an external buzzer for a successful barcode decoded (Good Read).																									
12	-----	USB D-	Bidirectional	Differential Signal Transmission																									

1-2-2. Electric Characteristics

Symbol	Ratings	Min	Max	Unit
V_{IH}	Input high level	$0.41*(V_{DD}-2)+1.3$	$V_{DD}+0.3$	V
V_{IL}	Input low level	0	$0.28*(V_{DD}-2)+0.8$	V
V_{OH}	Output high level	$V_{DD}-0.4$	-	V
V_{OL}	Output low level	-	0.4	V
$V_{ESD(HBM)}$	Electrostatic discharge voltage (human body model)	±4kV contact direct discharge, ±8kV indirect discharge. Requires housing that is designed for ESD protection and stray electric fields.		kV

***Note:**

1. Power Supply: V_{DD} = 3.3 or 5 V
2. Exposure to maximum rating conditions for extended periods may affect device reliability.

1-2-3. Flex Cable

The flex cable is used to connect MT40 with the host side. There are 12 pins on both the engine (MT40) side and the host side. Please see Chapter 2-10 for more details of flex cable.

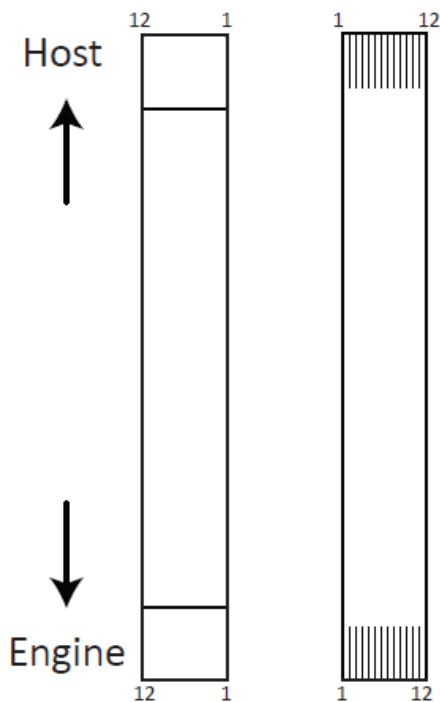

Flex cable (P/N: 67XX-1009X12)	
Pin#	Pin Assignment To Host
1	VCC
2	RXD
3	Trigger
4	Power Enable
5	TXD
6	RTS
7	GND
8	USB D+
9	LED
10	CTS
11	Buzzer
12	USB D-

***Note:** Conforms to MARSON MT742(L)/MT752(L) pin assignment.



1-3. Operational Timing

This chapter describes the timing associated with the various operating modes of the MT40 including Power Up, Sleep Mode, and Decode Timing.

1-3-1. Power Up

When power is initially applied, the MT40 is activated and begins the process of initialization. Once initialization (duration $\leq 10\text{mS}$) is completed, the MT40 enters **Standby Mode** and is ready for barcode scanning.

1-3-2. Sleep (Idle) Mode

The MT40 may enter **Sleep (Idle) Mode** after a programmable time period has elapsed without any activity. Please see Chapter 6 for more details about Sleep Mode.

1-3-3. Decode Timing

In **Standby Mode**, the MT40 is activated by the Trigger signal which **MUST** be kept low for at least 20 ms until the successful scan is achieved, as indicated by the Buzzer/LED signals.

In **Sleep Mode**, the MT40 can be waken up by the Trigger signal which **MUST** be kept low for at least 2 mS, which will prompt the scan engine into **Standby Mode**.

The total scan and decode time is approximately equal to the time from the Trigger signal going low to the Buzzer/LED signal going high. This time will vary slightly based on several factors including barcode quality, barcode type and the distance between MT40 and the barcode scanned.

Upon a successful scan, the MT40 outputs the Buzzer/LED signal and keeps this signal for the duration of the transmission of the data decoded to the host side. The duration is about 75 ms.

Therefore, the total duration of a typical scanning operation (from Trigger turning low to the end of Buzzer PWM signal) is also approximately 120mS.



1-3-4. Summary of Operation Timings

1. The maximum duration of initialization is 10mS.
2. The maximum duration of scanning operation in Standby Mode is 120mS.
3. The minimum duration of waking up MT40 from Sleep Mode by Trigger signal is about 2 ms.
4. The maximum duration of waking up MT40 from Sleep Mode by Trigger signal and completing decode (when barcode is within optimal focus) is about 120ms



2. SPECIFICATIONS

2-1. Introduction

This chapter provides technical specifications of the MT40 scan engine. Operating method, scanning range and scan angle are also presented.

2-2. Technical Specifications

Optic & Performance			
Light Source		625nm visible red LED	
Sensor		Linear Image Sensor	
Scan Rate		510 Scans/ sec (Smart Detection)	
Resolution		MT40: 4mil/ 0.1mm ; MT40W: 3mil/ 0.075mm	
Scan Angle		MT40: 40° ; MT40W: 65°	
Print Contrast Ratio		30%	
Width of Field (13Mil Code39)		MT40: 200mm ; MT40W: 110mm	
Depth Of Field (Environment: 800 lux)	Code \ Model	MT40	MT40W
	3 mil Code39	N/A	35 ~ 70mm (13 digits)
	4 mil Code39	60 ~ 130mm (4 digits)	25 ~ 80mm (4 digits)
	5 mil Code39	55 ~ 170mm (4 digits)	25 ~ 100mm (4 digits)
	10 mil Code39	30 ~ 350mm (4 digits)	20 ~ 160mm (4 digits)
	15 mil Code39	45 ~ 520mm (4 digits)	30 ~ 200mm (4 digits)
	13 mil UPC/ EAN	40 ~ 390mm (13 digits)	30 ~ 170mm (13 digits)
Physical Characteristics			
Dimension		(W)32 x (L)24 x (H)11.6 mm	
Weight		8g	
Color		Black	
Material		ABS	
Connector		12pin (pitch = 0.5mm) ZIF	
Cable		12pin (pitch = 0.5mm) flex cable	
Electrical			
Operation Voltage		3.3 ~ 5VDC ± 5%	
Working Current		< 160 mA	
Standby Current		< 80 mA	
Idle Current		< 8 mA (see Chapter 6 for Sleep/Idle Mode)	



MT40 Linear Image Scan Engine, Integration Guide, V1.7

Power Down Current	< 1 uA (see Chapter 1-2-1 for Power Enable pin)
Surge Current	< 500 mA
Connectivity	
Interface	UART (TTL-level RS232)
	USB (HID Keyboard)
User Environment	
Operating Temperature	-20°C ~ 60°C
Storage Temperature	-25°C ~ 60°C
Humidity	0% ~ 95%RH (Non-condensing)
Drop Durability	1.5M
Ambient Light	100,000 Lux (Sunlight)
Symbologies	UPC-A/ UPC-E EAN-8/ EAN-13 Matrix 2 of 5 China Postal Code (Toshiba Code) Industrial 2 of 5 Interleaved 2 of 5 Standard 2 of 5 (IATA Code) Codabar Code 11 Code 32 Standard Code 39 Full ASCII Code 39 Code 93 Code 128 EAN/ UCC 128 (GS1-128) MSI/ UK Plessey Code Telepen Code GS1 Databar
Regulatory	
ESD	Functional after 4KV contact, 8KV air discharge (it requires housing that is designed for ESD protection and stray from electric fields.)
EMC	FCC – Part15 Subpart B (Class B) CE – EN55022, EN55024
Safety Approval	IEC 62471 (Exempt Group)
Environmental	WEEE, RoHS 2.0



2-3. Interface

2-3-1. UART Interface

Below default values of communication parameters apply to both Standard mode and Command mode firmware.

Baud rate: 9600

Data Bits: 8

Parity: None

Stop Bit: 1

Handshaking: None

Flow Control Timeout: None

ACK/NAK: OFF

BCC: OFF

A. Standard Mode

Firmware version: [SM3-k-x.xx](#)

(MT40 P/N: [1040-A000000](#) ; MT40W P/N: [1040-A000001](#))

Characteristics:

- (1) Configurable by scanning configuration barcodes or Ez Utility® (a PC-based software utility, available for download at www.marson.com.tw)
- (2) Supports hardware trigger only

Interface Configuration Barcode:

. C002\$



UART

Scanning above barcode will set your MT40 to UART interface.



B. Command Mode

Firmware version: [SM3-k-x.xx.CMD](#)

(MT40 P/N: [1040-4000000](#) ; MT40W P/N: [1040-4000001](#))

Characteristics:

- (1) Configurable by commands sent from host or BEO® (a PC-based software utility, available for download at www.marson.com.tw)
- (2) Supports both hardware and software triggers

Interface Configuration Barcode:

Not supported.

2-3-2. USB Interface

Firmware version: [SM3-k-x.xx](#)

(MT40 P/N: [1040-A000000](#) ; MT40W P/N: [1040-A000001](#))

Characteristics:

- (1) Configurable by scanning configuration barcodes or Ez Utility® (a PC-based software utility, available for download at www.marson.com.tw)
- (2) Supports hardware trigger only
- (3) Emulates a USB Keyboard device

Interface Configuration Barcode:

. C008\$



USB HID

Scanning above barcode will set your MT40 to USB interface.

2-4. Operation Method

1. At power-up, the MT40 sends the Power-Up signals over Buzzer and LED pins as an indication that the MT40 enters **Standby Mode** and is ready for operation.
2. Once the MT40 triggered by either hardware or software method, it will emit a narrow, horizontal slab of light which is aligned with the sensor's field of view.
3. The linear image sensor captures the linear image of barcode and produces an analog waveform, which is sampled and analyzed by the decoder firmware running on the MT40.
4. Upon a successful barcode decoded, the MT40 turns off the illumination LEDs, sends the Good Read signals over Buzzer and LED pins and transmits the decoded data to the host.
5. The MT40 may enter **Sleep Mode** (Please see Chapter 6 for more details) after a period of inactivity in order to reduce power consumption.

2-5. Mechanical Dimension

(Unit = mm)

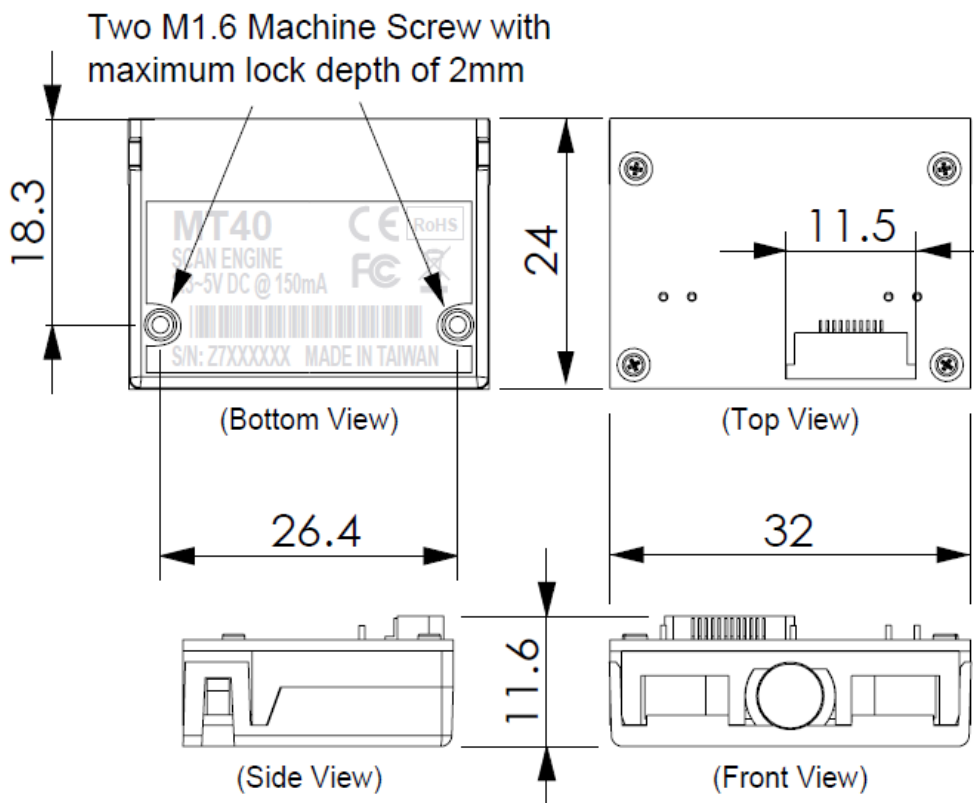

2-6. Scanning Range

Test Condition - MT40

Barcode Length: Code39 – 4 characters
 EAN/UPC – 13 characters
 Bar & Space Ratio: 1 to 2.5
 Print Contrast Ratio: 0.9
 Ambient Light: > 800 lux

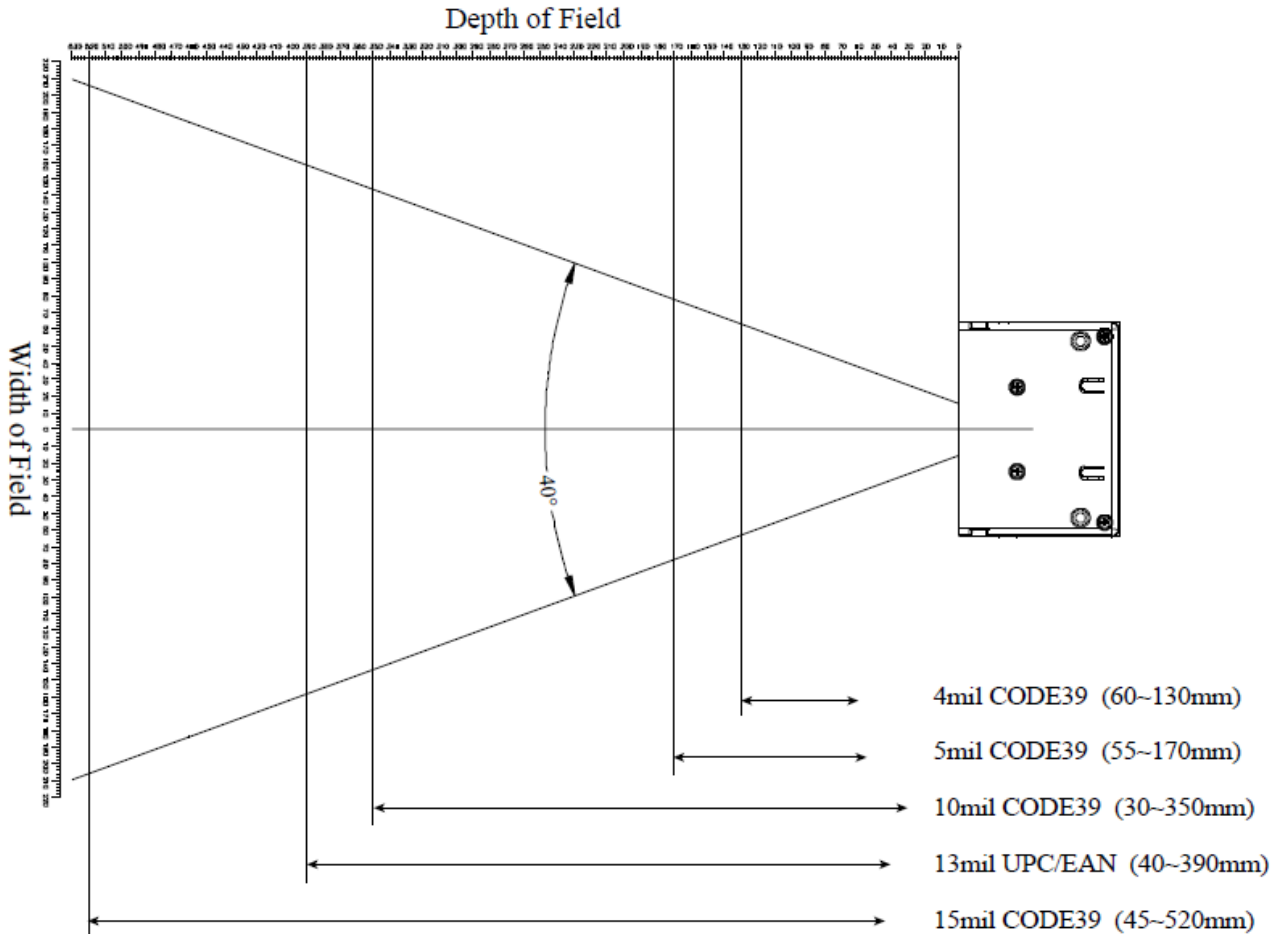

Minimum & Maximum Scan Distance of MT40

Symbology	Resolution	Distance	No. of Encoded Characters
Standard Code 39 (w/o checksum)	4 Mil	60 ~ 130 mm	4 char.
	5 Mil	55 ~ 170 mm	
	10 Mil	30 ~ 350 mm	
	15 Mil	45 ~ 520 mm	
EAN 13	13 Mil	40 ~ 390 mm	13 char.

Maximum Scan Width of MT40

Symbology	Resolution	Barcode Length	No. of Encoded Characters
Standard Code 39 (w/o checksum)	13 Mil	200 mm	37 char.



MT40 Linear Image Scan Engine, Integration Guide, V1.7

Test Condition - MT40W

Barcode Length: Code39 3mil – 13 characters, Code39 4/5/10/15mil – 4 characters
 EAN/UPC – 13 characters
 Bar & Space Ratio: 1 to 2.5
 Print Contrast Ratio: 0.9
 Ambient Light: > 800 lux

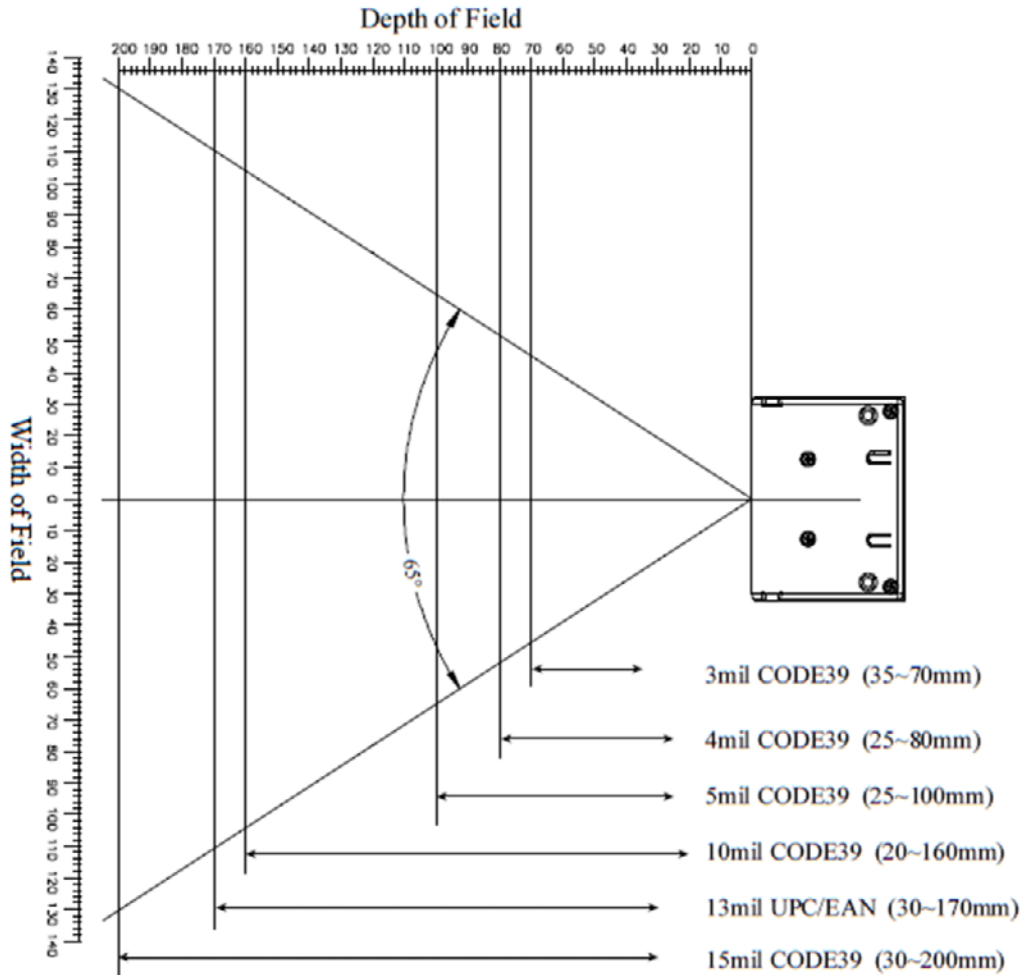

Minimum & Maximum Scan Distance of MT40W

Symbology	Resolution	Distance	No. of Encoded Characters
Standard Code 39 (w/o checksum)	3 Mil	35 ~ 70 mm	13 char.
	4 Mil	25 ~ 80 mm	4 char.
	5 Mil	25 ~ 100 mm	
	10 Mil	20 ~ 160 mm	
	15 Mil	30 ~ 200 mm	
EAN 13	13 Mil	30 ~ 170 mm	13 char.

Maximum Scan Width of MT40W

Symbology	Resolution	Barcode Length	No. of Encoded Characters
Standard Code 39 (w/o checksum)	13 Mil	110 mm	19 char.

2-7. Pitch Angle, Roll Angle and Skew Angle

Be aware of the tolerance for the pitch, roll and skew angle of bar code you are trying to scan.

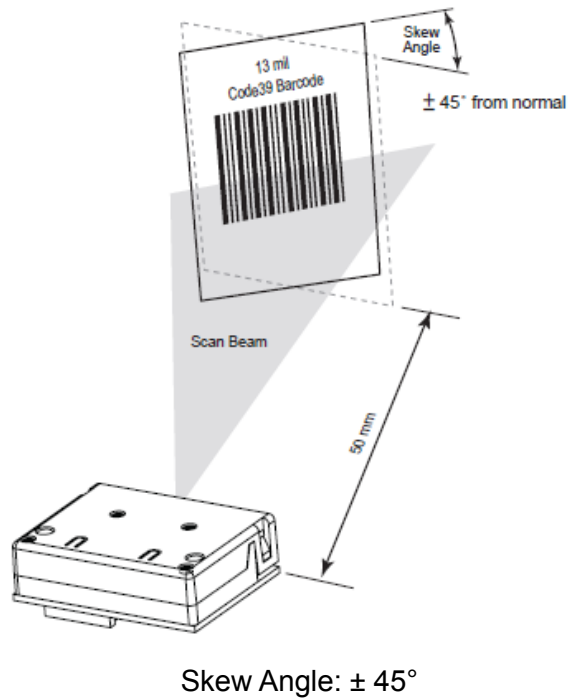
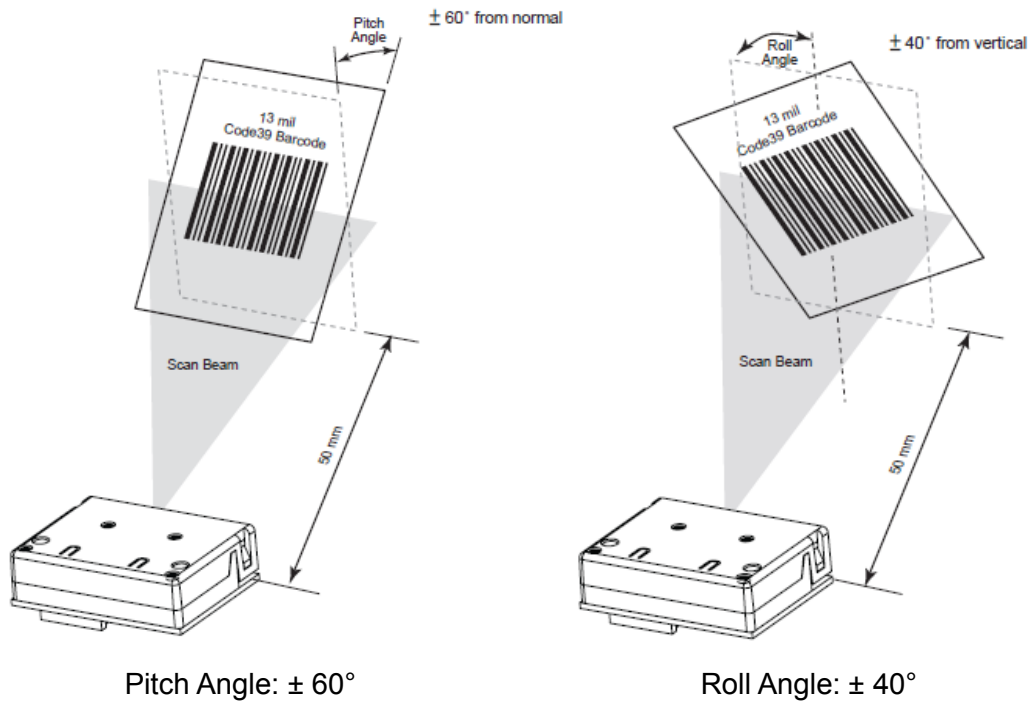



2-8. Specular Dead Zone

Do not place the MT40 directly over the barcode. The light reflecting directly back into the MT40 from the barcode is known as specular reflection, which can make decoding difficult. The specular dead zone of MT40 is up to 5° depending on target distance and substrate glossiness.

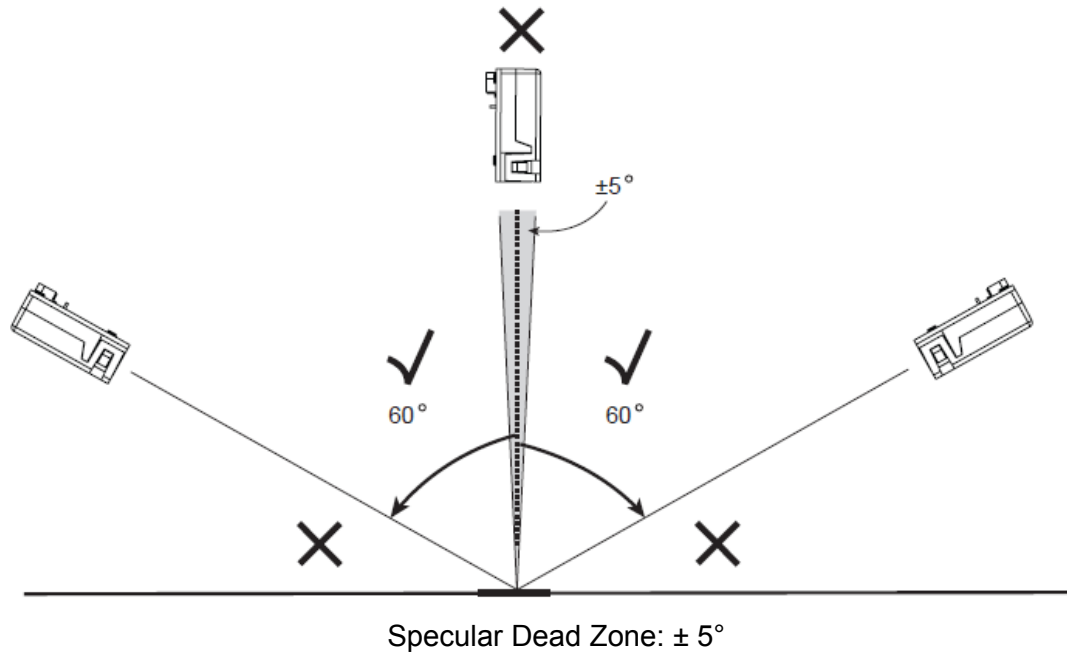

2-9. Curvature Degree

The curvature degree of a scanned barcode is specified as below:

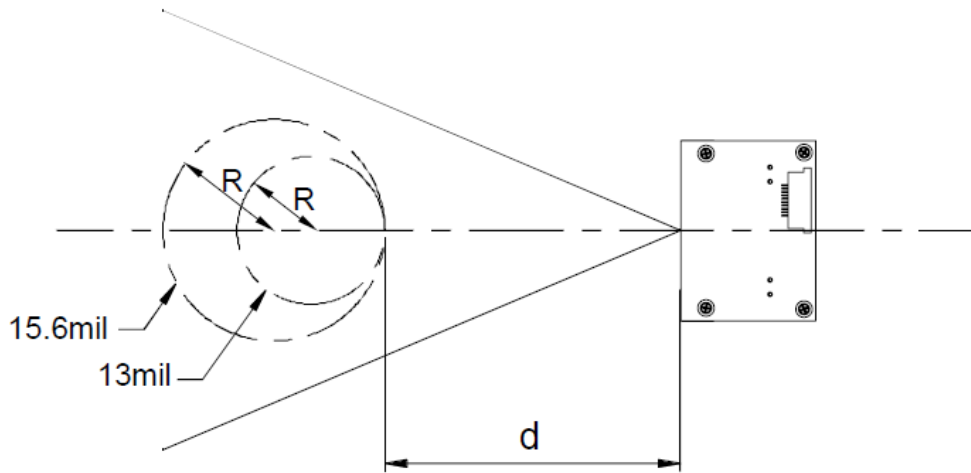

Barcode	EAN13 (L=37mm)	
Resolution	13 mil (0.33 mm)	15.6 mil (0.39 mm)
R	$R \geq 20$ mm	$R \geq 25$ mm
d (MT40)	90 mm	120 mm
d (MT40W)	40 mm	50 mm
PCS	0.9 (printed on photographic paper)	

2-10. Flex Cable Specification

Below is the drawing of flat cable(P/N: 67XX-1009X12) that comes with MT40.

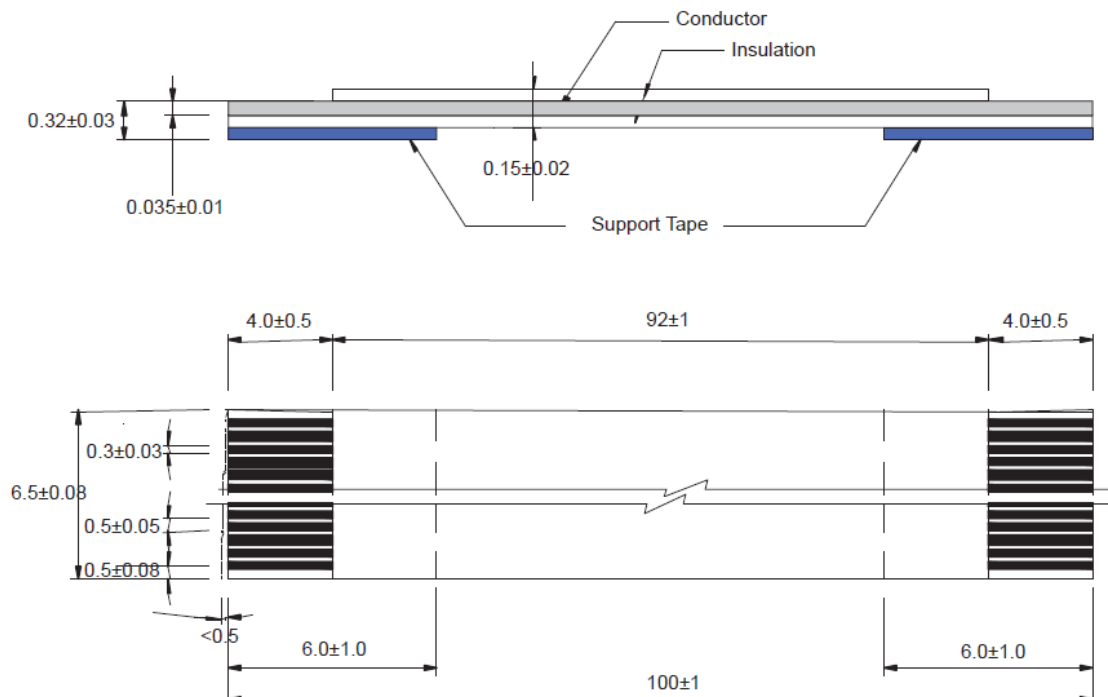

2-11. Screw Specification

Below is the drawing of M1.6x4 screws(P/N: 4210-1604X01) that come with MT40.

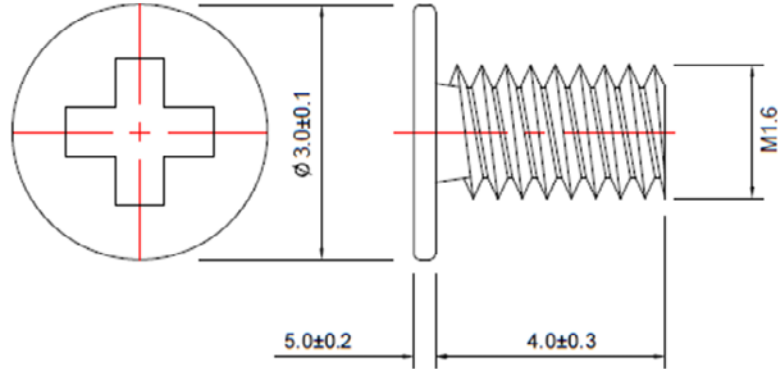

2-12. Connector Specification

Below is the drawing of 12-pin 0.5-pitch FPC Connector(P/N: 4109-0050X00) of MT40.

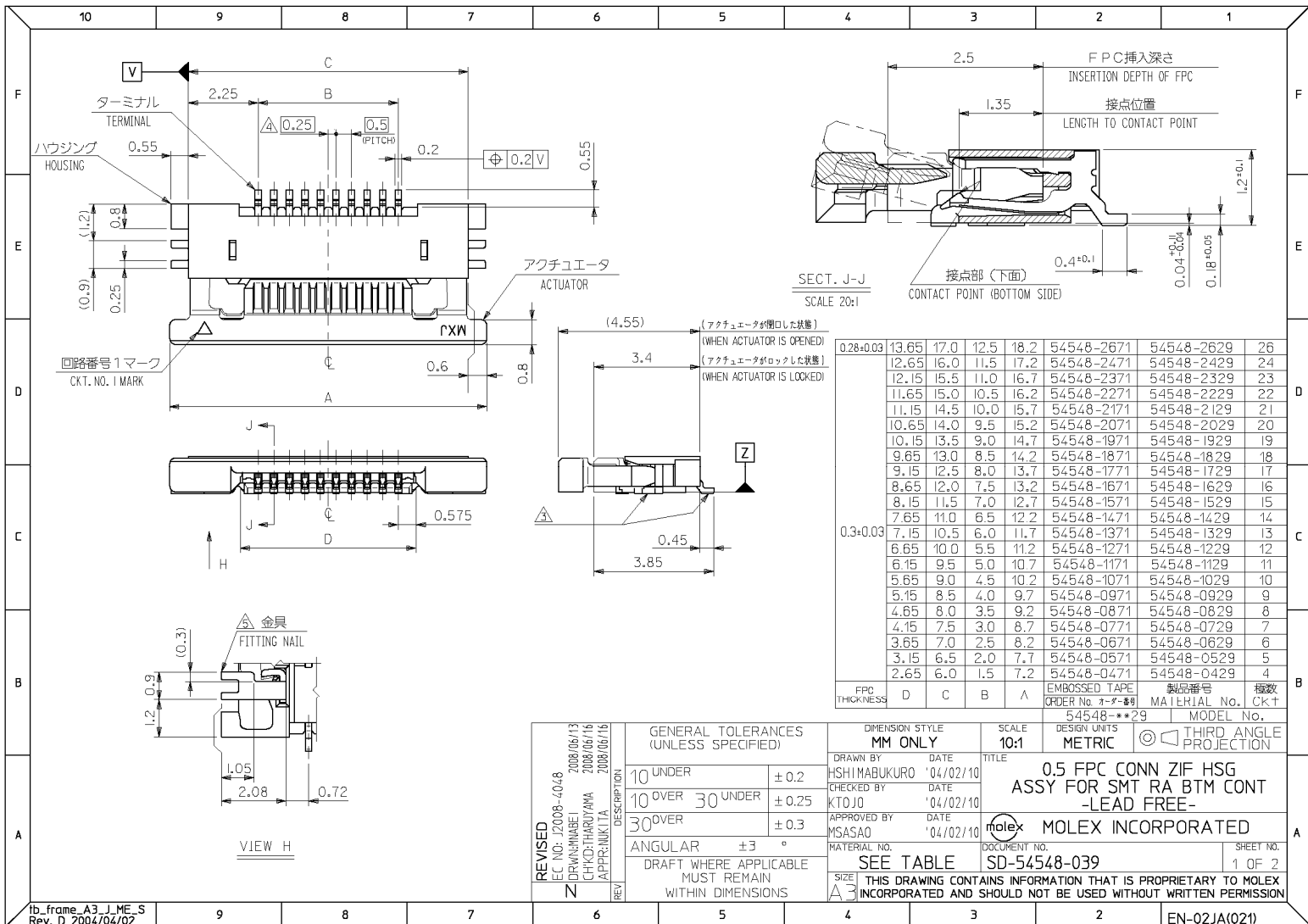

3. INSTALLATION

The MT40 scan engine is designed specifically for integration into customer's housing for OEM applications. However, the MT40's performance will be adversely affected or permanently damaged when mounted into an unsuitable enclosure.

Warning: The limited warranty is void if the following recommendations are not adhered to when mounting the MT40.

3-1. Electrostatic Discharge Cautions

All MT40s are shipped in ESD protective packaging due to the sensitive nature of the exposed electrical components.

1. ALWAYS use grounding wrist straps and a grounded work area when unpacking and handling the MT40.
2. Mount the MT40 in a housing that is designed for ESD protection and stray electric fields.

3-2. Mechanical Dimension

When securing the MT40 by utilizing the machine screws:

1. Leave sufficient space to accommodate the maximum size of the MT40.
2. Do not exceed 1kg-cm (0.86 lb-in) of torque when securing the MT40 to the host.
3. Use safe ESD practices when handling and mounting the MT40.

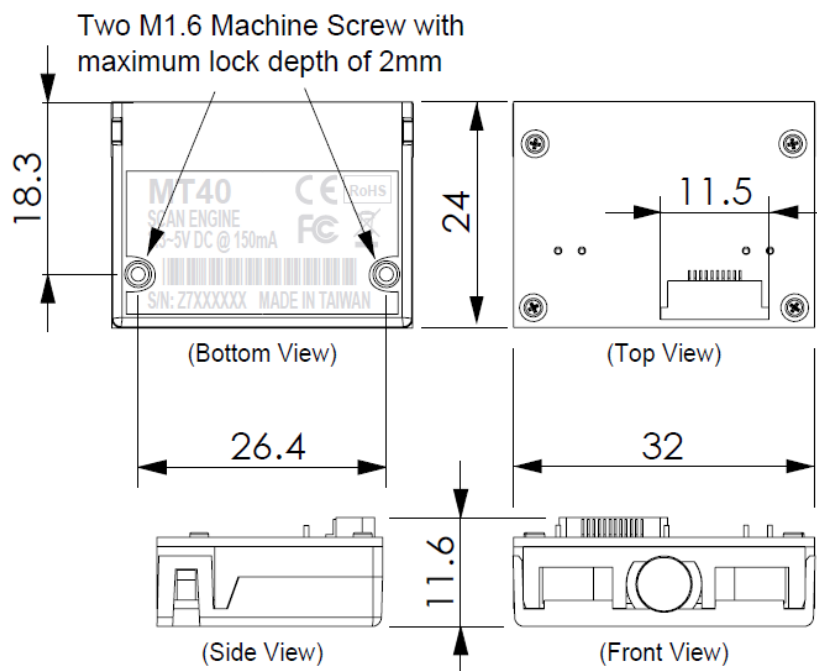



3-3. Window Materials

Following are descriptions of three popular window materials:

1. Poly-methyl Methacrylic (PMMA)
2. Allyl Diglycol Carbonate (ADC)
3. Chemically tempered float glass

Cell Cast Acrylic (ASTM: PMMA)

Cell cast Acrylic, or Poly-methyl Methacrylic is fabricated by casting acrylic between two precision sheet of glass. This material has very good optical quality, but is relatively soft and susceptible to attack by chemicals, mechanical stress and UV light. It is strongly recommended to have acrylic hard-coated with Polysiloxane to provide abrasion resistance and protection from environmental factors. Acrylic can be laser-cut into odd shapes and ultrasonically welded.

Cell Cast ADC, Allyl Diglycol Carbonate (ASTM: ADC)

Also known as CR-39™, ADC, a thermal setting plastic widely used for plastic eyeglasses, has excellent chemical and environmental resistance. It also has an inherently moderate surface hardness and therefore does not require hard-coating. This material cannot be ultrasonically welded.

Chemically Tempered Float Glass

Glass is a hard material which provides excellent scratch and abrasion resistance. However, un-annealed glass is brittle. Increased flexibility strength with minimal optical distortion requires chemical tempering. Glass cannot be ultrasonically welded and is difficult to cut into odd shapes.

Property	Description
Spectral Transmission	85% minimum from 635 to 690 nanometers
Thickness	< 1 mm
Coating	Both sides to be anti-reflection coated to provide 1% maximum reflectivity from 635 to 690 nanometers at nominal window tilt angle. An anti-reflection coating can reduce the light that is reflected back to the host case. Coatings will comply with the hardness adherence requirements of MIL-M-13508.

3-4. Window Specifications

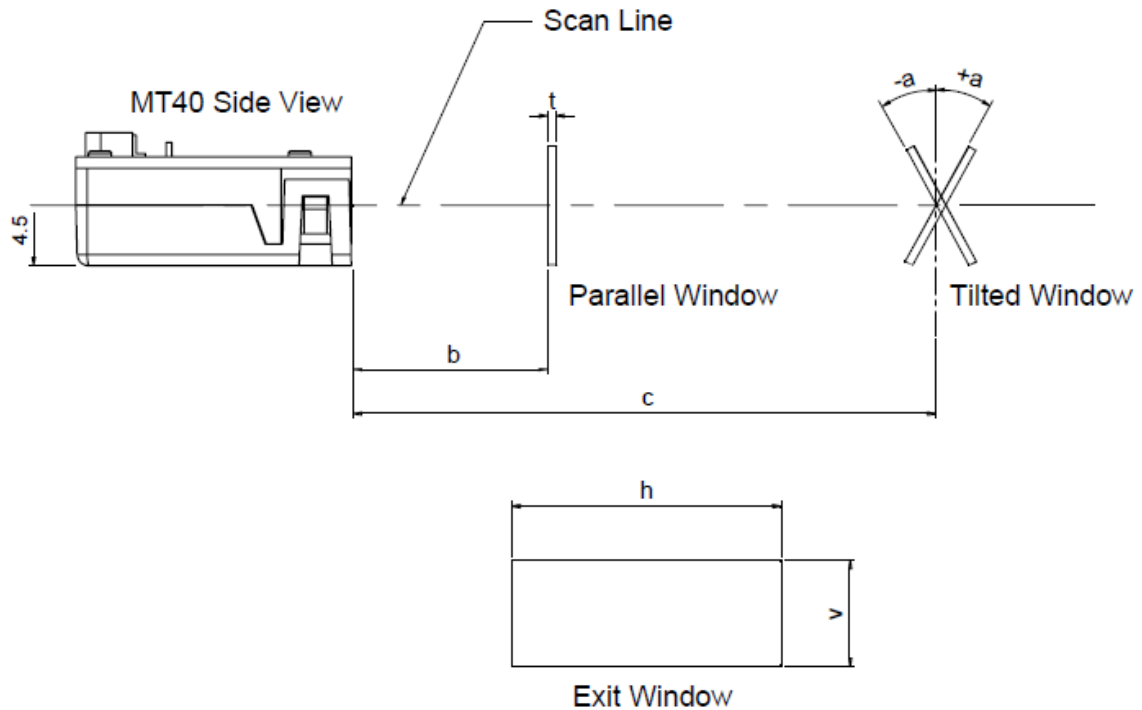

Window Specifications for MT40 Integration					
Distance	Tilt Angle (a)		Minimum Window Size		
			Horizontal (h)	Vertical (v)	Thickness (t)
0 mm (b)	0	0	32 mm	8 mm	< 1 mm
10 mm (c)	+20°~	-20°~	40 mm	11 mm	
20 mm (c)	+12°~	-12°~	45 mm	13 mm	
30 mm (c)	+8°~	-8°~	50 mm	15 mm	

Window Specifications for MT40W Integration					
Distance	Tilt Angle (a)		Minimum Window Size		
			Horizontal (h)	Vertical (v)	Thickness (t)
0 mm (b)	0	0	32 mm	8 mm	< 1 mm
10 mm (c)	+20°~	-20°~	45 mm	11 mm	
20 mm (c)	+12°~	-12°~	55 mm	13 mm	
30 mm (c)	+8°~	-8°~	65 mm	15 mm	

The window size must increase as it is moved away from MT40 and should be sized to accommodate the field of view and illumination envelopes shown below:

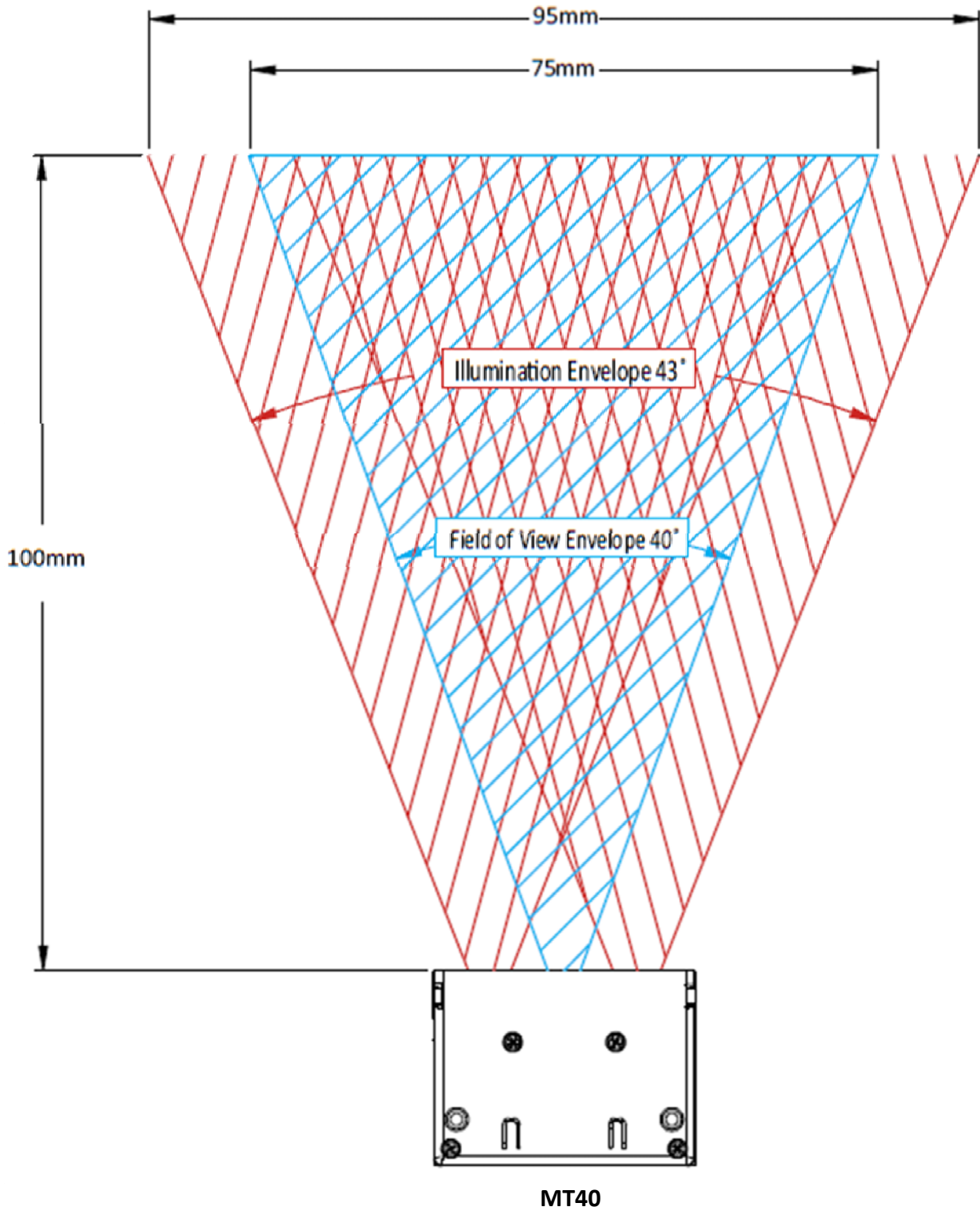

The window size must increase as it is moved away from MT40W and should be sized to accommodate the field of view and illumination envelopes shown below:

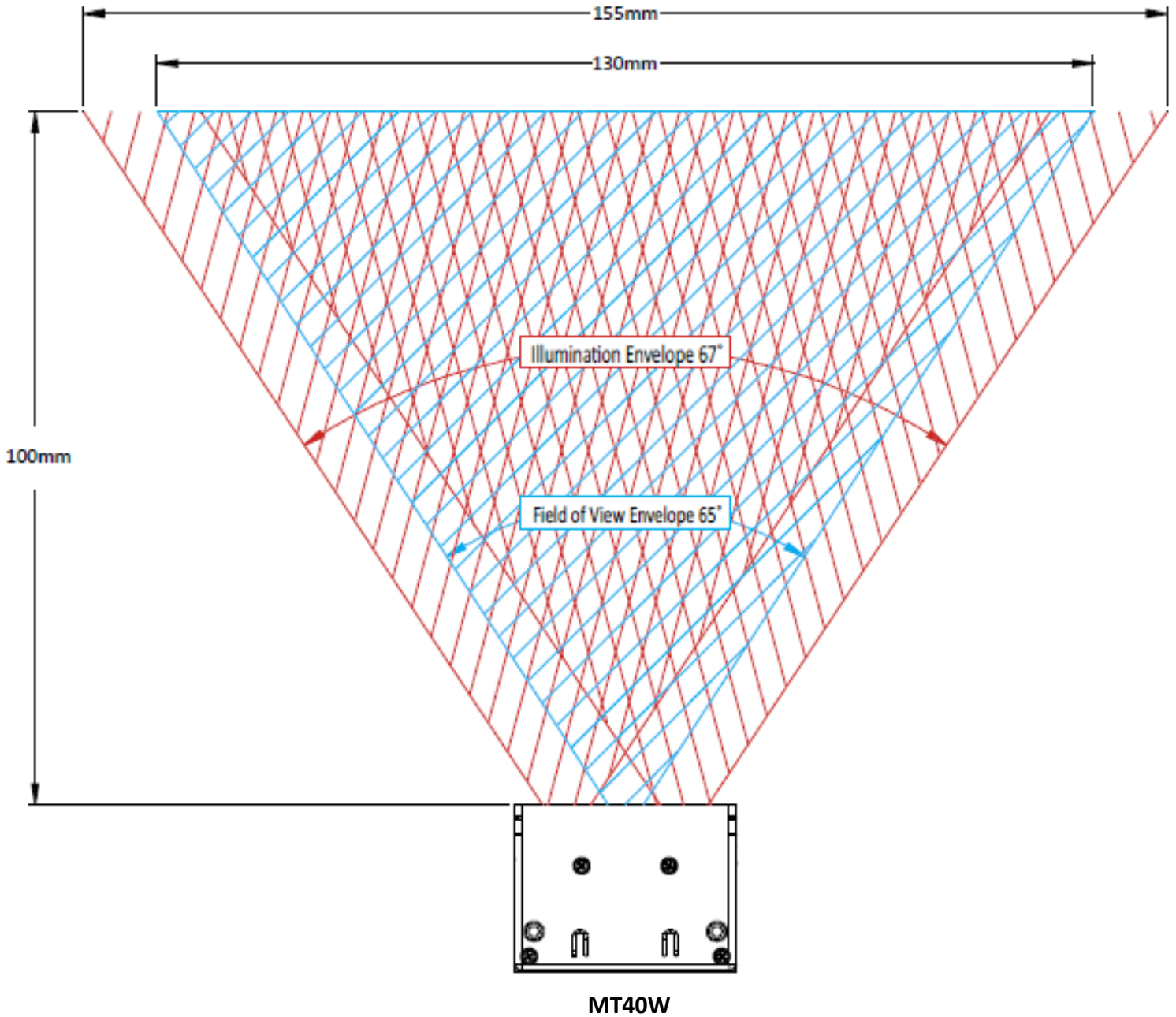



3-5. Window Care

In the aspect of window, the performance of MT40 will be reduced due to any kind of scratch. Thus, reducing the damage of window, there are few things have to be noticed.

1. Avoid touching the window as much as possible.
2. When cleaning the window surface, please use non-abrasive cleaning cloth, and then gently wipe the host window with the cloth that is already sprayed with glass cleaner.

4. REGULATIONS

The MT40 scan engine conforms to the following regulations:

1. Electromagnetic Compliance – CE EN55022, EN55024
2. Electromagnetic Interference – FCC Part15 Subpart B (Class B)
3. Photobiological Safety – IEC 62471 (Exempt Group)
4. Environmental Regulations – RoHS 2.0, WEEE

5. DEVELOPMENT KIT

MARSON MB100 Demo Kit (P/N: [11A0-9801A20](#)) enables the development of products and systems using the MT40 on the MS Windows OS platform. Besides the Multi I/O board (P/N: [2006-1007X00](#)), the MB100 Demo Kit provides the software and hardware tools required for testing the MT40 applications before integrating it into the host device. Please contact your sales representative for ordering information.

MB100 Multi I/O Board (P/N: [2006-1007X00](#))



Connects to MT40(W).....

MB100 Demo Kit Accessories

O: Supported X: Not Supported

Cable	Interface	RS232	USB HID	USB VCP
	External Y-cable (P/N: 7090-1583A00)		O	O
Internal Y-cable (P/N: 5300-1315X00)		O	O	O
Micro USB Cable (P/N: 7005-9892A50)		X	O	O

Due to the advantage of its small size, MB100 Multi I/O board is also suitable for being installed inside the host system, as an interface board connecting MT40 to the host device.

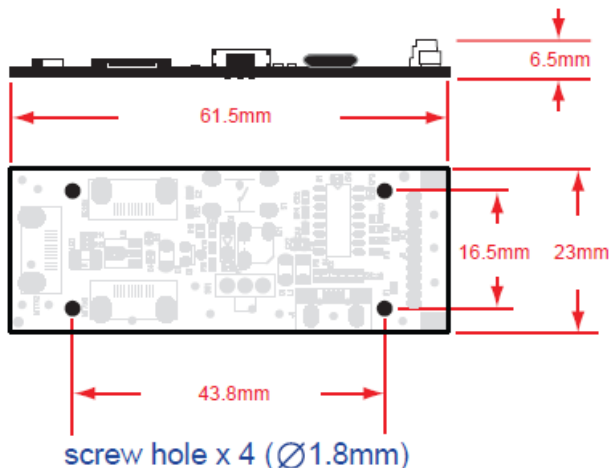



6. SLEEP (IDLE) MODE

The **Sleep (Idle) Mode** is disabled by default. To enable **Sleep (Idle) Mode**, simply follow below instruction to configure the “Pre-Idle Time”, or the period of inactivity before MT40 enters Sleep (Idle) Mode, as appropriate.

A. Standard Mode

Firmware version: [SM3-k-x.xx](#)

(MT40 P/N: [1040-A000000](#) ; MT40W P/N: [1040-A000001](#))

Steps:

1. Scan SET MINUTE [.B030\$] or SET SECOND [.B029\$]
2. Scan two digit from the numeric barcode table below.
3. Scan SET MINUTE [.B030\$] or SET SECOND [.B029\$]

Notes:

Pre-Idle Time - Min: 10 sec, Max: 60 min & 60 sec

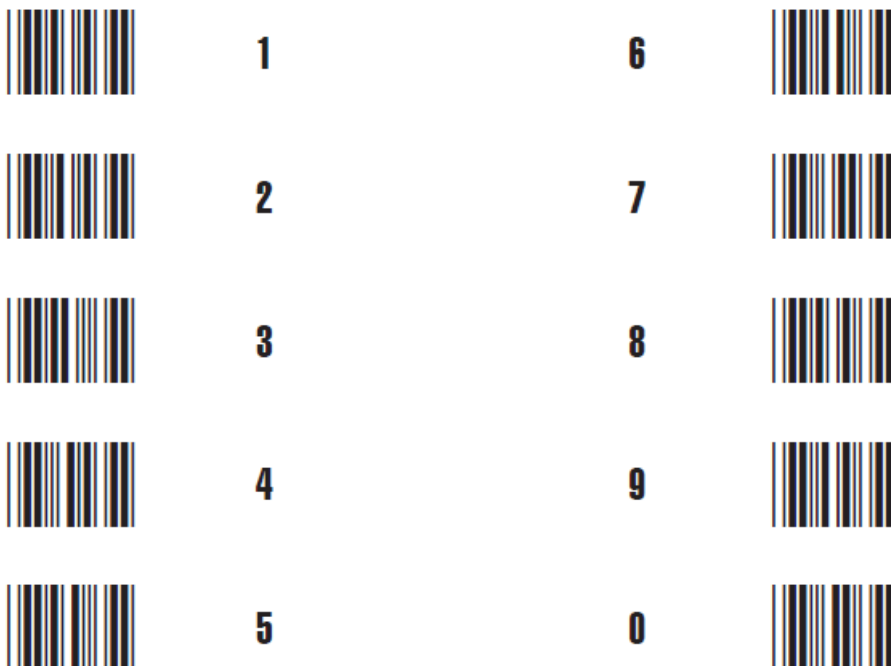



B. Command Mode

Firmware version: SM3-k-x.xx.CMD

(MT40 P/N: 1040-4000000 ; MT40W P/N: 1040-4000001)

Property	Option	Remark
Sleep (Idle) Mode {MC11WT1}	0 Off 1 On	Default : Off When enabled, scanner will automatically enter Sleep Mode after a period of inactivity(Sleep Mode timeout).
Pre-Idle Time {MC11WT,1,0}	A number from 0~60 (Minute) A number from 0~60 (Second)	Default : 1 minute Sleep Mode timeout(10 sec ~ 60 min & 60 sec), the period of inactivity before the scanner enters Sleep Mode .

Steps:

1. Send {MC11WT1} & {MC11WT,1,0} to the MT40 if you want to enable **Sleep (Idle) Mode** and set Pre-Idle Time as 1 minute.
2. The MT40 will return {MC11,OK} and {MC11,1,1,0} respectively as confirmation.
3. If you want above settings to be saved permanently in Flash ROM, send {MCMDWT1} to the MT40. Otherwise MT40 will be reset to default after wake up from sleep.

Notes:

Curly braces “{ }” must be included at both ends of each command.

7. PARAMETER SETUP

You can set up your MT40 using one of the following methods:

1. Standard Mode (F/W ver.: SM3-k-x.xx):

Scan configuration barcodes from the Universal User’s Manual, or use Ez Utility®, both of which are available for download at www.marson.com.tw

2. Command Mode (F/W ver.: SM3-k-x.xx.CMD):

Send software commands from the host, or use BEO®, which is available for download at www.marson.com.tw. Full list of software commands can be found in the Help File of BEO program, on the chapter *Test Window/ Command Operation*.



8. VERSION HISTORY

Rev.	Date	Description	Issued	Checked
1.0	2016.09.08	Initial Release	Shaw	Kenji & Hus
1.1	2016.09.29	Revised Roll/Skew Angle Drawings	Shaw	Kenji & Hus
1.2	2016.10.31	Revised Sleep Mode command in Chapter 6	Shaw	Kenji & Hus
1.3	2016.12.23	Updated MT40 D.O.F.	Shaw	Kenji & Hus
1.4	2017.06.21	Deleted Red Cell-Cast Acrylic Description	Shaw	Hus
1.5	2017.07.27	Revised Scan Rate, Working/Standby Current	Shaw	Kenji
1.6	2017.08.09	Revised D.O.F. & Operating/Storage Temp.	Shaw	Kenji & Hus
1.7	2018.03.15	Updated Chapter 1 and 1-1 on MCU. Updated Chapter 6 on Command Mode settings.	Shaw	Kenji & Hus

Marson Technology Co., Ltd.

9F., 108-3, Mincyuan Rd., Sindian Dist., New Taipei City, Taiwan

TEL: 886-2-2218-1633

FAX: 886-2-2218-6638

E-mail: info@marson.com.tw

Web: www.marsontech.com